

MUTO Premium XL150/80

Ceiling mount with Dormotion (Glass door)

Installation Manual

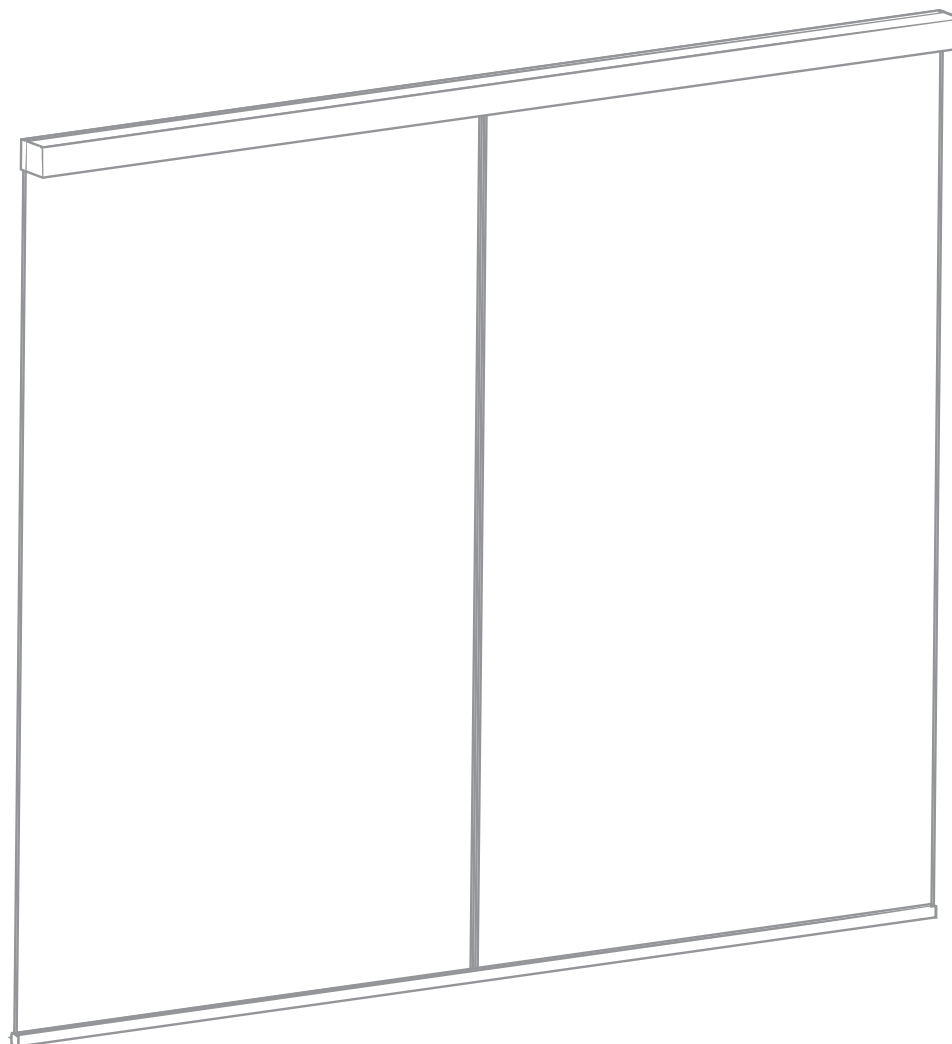

Table of contents

1	Technical specifications	3
1.1	Overview	3
	1.1.1 General information	3
	1.1.2 Intended use	3
	1.1.3 Glass requirements and fittings	3
	1.1.4 Requirements for glass panel	3
	1.1.5 Safety instructions	3
	1.1.6 Symbols used - Safety/Installation	3
	1.1.7 Maintenance, care, repair	3
	1.1.8 Disposal	3
1.2	Specifications - technical data	4
1.3	Tempered laminate glass (TLG) and adhesive specifications	4
2	Installation instructions	5
2.1	Overall	5
2.2	Securing track to mounting surface	6
2.3	Door/wall dimensions	7
2.4A	Installing roller carriers: on monolithic glass ONLY	8
2.4B	Installing roller carriers: on tempered laminate glass ONLY	9
2.5	Install DORMOTION start/stop	10
2.6	Disengaging the anti-jump	10
2.7	Installing end stops	11
2.8	Install glass/rollers in track	11
2.9	Install floor guide	12
2.10	Install floor guide: continued	12
2.11	Engaging anti-jump	13
2.12	Adjustment door height	13
2.13	Adjustment end stop location: LEADING end stop	14
	Adjustment end stop location: TRAILING end stop	14
2.14	Install DORMOTION units	15
2.15	Adjust start/stop pin height (if necessary)	17
2.16	Cover clips	18
2.17	Install brush profile	18
2.18	Install view protection clips	19
2.19	Install cover and view protection profile	20
2.20	Install end caps	20

1 Technical specifications

1.1 Overview

These instructions are for installation of MUTO PREMIUM sliding door system XL150/80 for the following mounting and style versions:

1. Ceiling mount

1.1.1 General information

- dormakaba requires use of tempered monolithic or tempered laminated glass.
- dormakaba glass hardware is not suitable for application in rooms where chemicals (e.g. chlorine) are used as indoor swimming pools, saunas or salt-water pools.
- Never move sliding panels faster than walking speed and always stop the door manually before it reaches end position.
- Do not slide doors with excessive force. Install limiting stop to prevent door from opening too far.

1.1.2 Intended use

- For sliding door in dry indoor areas only
- For manual slowly opening and closing only

1.1.3 Glass requirements and fittings

- The substructure/wall must be able to bear permanent loads and be level (max. tolerance: 1/16" [2] per 39" [1m]).
- Fasteners must be sufficiently dimensioned for the substructure/wall and weight of the door.
- When adjusting glass components, always stick to the required clearance for the respective hardware. Adjust clearance so glass does not come in contact with any hard surfaces such as glass, metal or concrete.
- Do not use excessive force when installing the glass (avoid over tightening screws).

1.1.4 Requirements for glass panel

- dormakaba requires use of fully tempered glass, which complies with ASTM C 1036 and ASTM C 1048. Secondary heat soaking processes are optional but not required. This applies to both tempered monolithic and tempered laminated glass.
- Clamping area must be flat and uncoated (no self-cleaning coating!)
- Never use glass with conchoidal fractures and/or damaged edges.

1.1.5 Safety instructions

- Installation requires two people.

- Only properly qualified and specially trained staff are authorized to mount dormakaba glass hardware.
- Due to crushing hazards and possible injury caused by breakage of glass during mounting, corresponding protective clothing (especially gloves and protective goggles) is required.
- Never clamp metal fitting hardware directly to glass surface.

1.1.6 Symbols used - Safety/Installation



CAUTION

Mounting components must meet the requirements of substructure/wall and door weight. Please read the technical information for fittings.



WARNING

Risk of breaking glass. When installing the door, support the door panel with a block of wood or similar object.



TIPS AND RECOMMENDATIONS

Information note



CLOSING EDGE

1.1.7 Maintenance, care, repair

- Immediately replace damaged parts.
- Always use original dormakaba parts.
- Clean clamping area with alcohol-based standard commercial cleaning agent before mounting the glass hardware.
- Use a damp clothe for occasional cleaning, especially the track.
- Always use silicone - and oil-free cleaners (e.g. acetone).
- Check glass hardware at regular intervals for proper positioning and smooth operation and correct adjustment.
- High traffic door systems require inspection by properly qualified staff (specialized companies or installation firms.)

1.1.8 Disposal

Disposal in accordance with local, state and national regulations.

1.2 Specifications - technical data

		Single Door		Double Door	
		XL150	XL80	XL150	XL80
Ceiling mount	Door leaf weight lbs [kg]*	≤330lbs [≤150]	≤176lbs [≤80]	≤330lbs [≤150]	2 x ≤176lbs [2 x ≤80]

* Including weight of auxiliary hardware.

1.3 Tempered laminate glass (TLG) and adhesive specifications

Required parts for laminate glass with MUTO System (not included)	Part Number	Quantity	Usage recommendation
3M™ Scotch-Weld™ Urethane Adhesive, DP 605 NS	934.800	1 tube	1 tube per 4 roller carriers
3M™ Scotch-Weld™ EPX™ Plus II Applicator with 1:1 Plunger ²	934.801	1 applicator	1:1 plunger with 934.800 adhesive
3M™ Scotch-Weld™ EPX™ Plus II Mixing Square Nozzle, 5.3mm ³	934.805	Pk of 4	4 nozzles per 1 tube of adhesive
MUTO TLG gasket set	807.640	1 set	
Handling time frame	Function	Time	
	Working life (<i>time between application and clamping of carrier</i>)	5 minutes @ 75°F	
	Handling strength	20 minutes @ 73°F or more	
	Full cure time (<i>normal door usage not recommended until full cure time as been met</i>)	48 hours @ 73°F or more	

NOTE: Door glass should not be installed until the full cure time as been reached (see chart above).

Important safety-related information for the mounting and use of dormakaba glass hardware.

1.3.1 Clean clamping area with alcohol-based standard commercial cleaning agent before mounting the glass hardware.

1.3.2 Never clamp metal glass fitting hardware directly to glass surface.

1.3.3 Never use clamping product on surfaces with self-cleaning coatings.

² Scotch-Weld™ EPX™ Plus II Applicator with 1:1 Plunger is a trademark of 3M.

³ Scotch-Weld™ EPX™ Plus II Mixing Square Nozzle is a trademark of 3M.

2 Installation instructions

2.1 Overall

Fig. 1

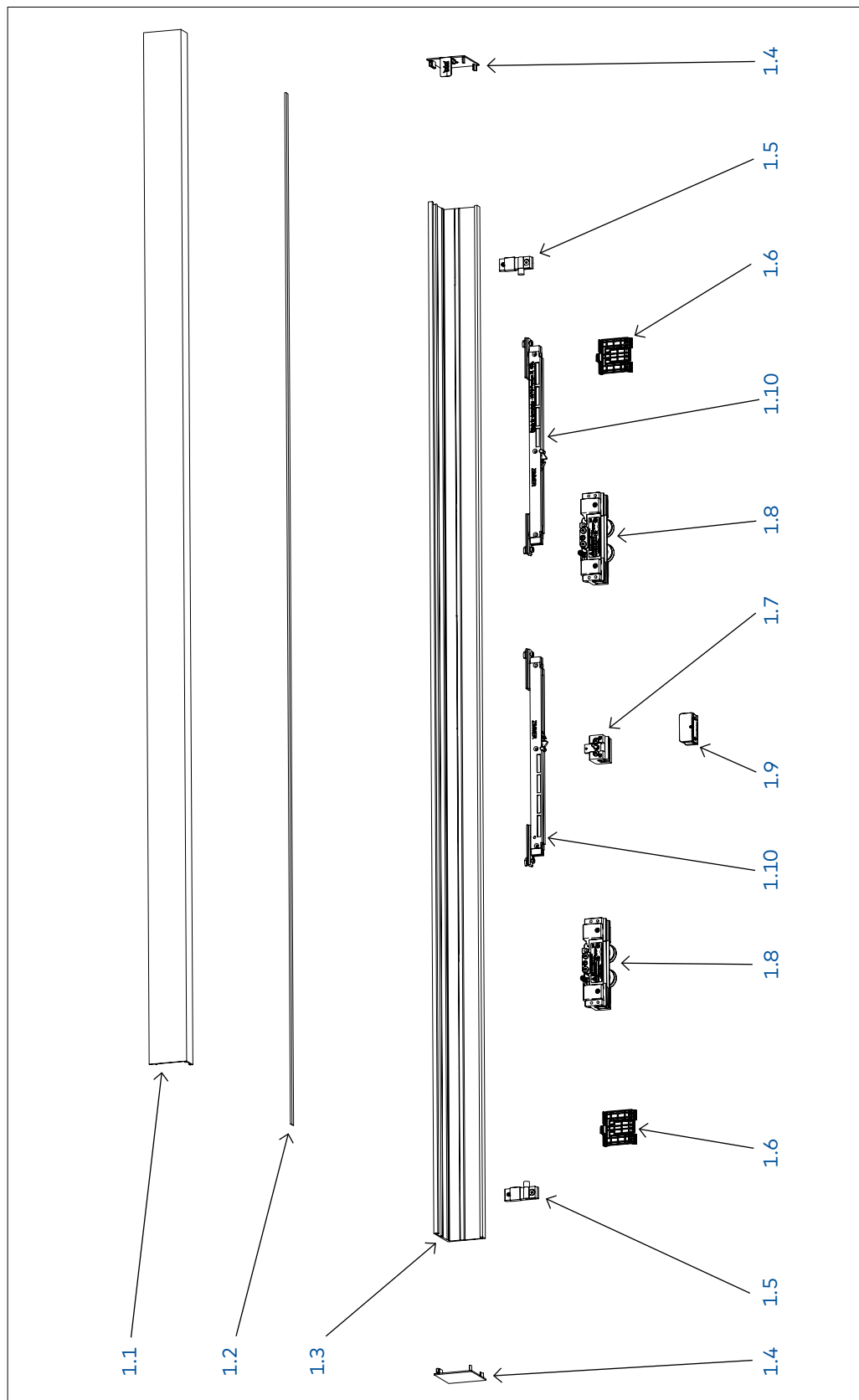

- 1.1 Cover
- 1.2 Brush strip
- 1.3 Track
- 1.4 Floor guide
- 1.5 Brush strip
- 1.6 Dormotion units
- 1.7 Start/stop guide
- 1.8 Roller carriers
- 1.9 End stop (x2)
- 1.10 Cover clips

2.2 Securing track to mounting surface

Fig. 2

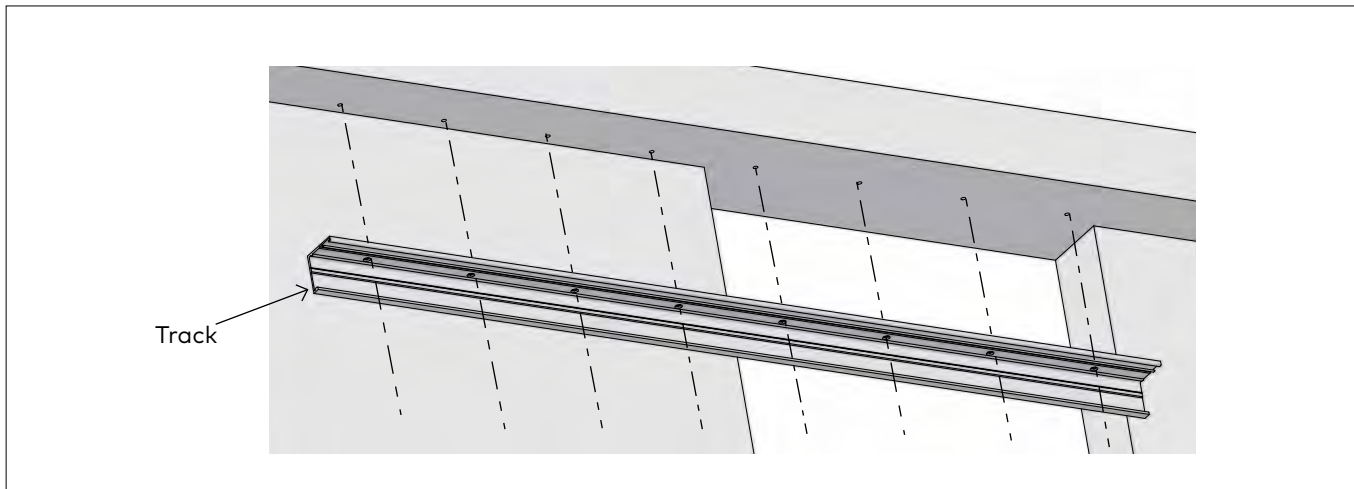

2.2.1 Ensure the track is properly level and secure it to the ceiling per the appropriate measurements on the following page.

- **NOTE: SEE DIMENSION INSTRUCTIONS ON NEXT PAGE FOR REFERENCE.**

NOTE:

OVERHEAD REINFORCEMENT:

The overhead reinforcement must be a minimum of ¼" [6] x 3" [76] steel angle, 16 gauge metal stud, or two pieces of 1-1/2" [38] thick wood blocking [double stacked], secured to studs or joists on a maximum 16" [406] centers for the length of the track. The overhead reinforcement may be flush on the overhead surface or on the interior of this surface.

2.2.2 Use appropriate fasteners according to the following recommendations.

Track mounting screws must fully penetrate the steel angle, metal stud, or at a minimum of 2" [51] into wood blocking, utilizing the predrilled holes in the MUTO track.

Consult with a structural engineer to determine if reinforcement is adequate for your specific application or to meet specific codes in your location.

2.3 Door/wall dimensions

Fig. 3

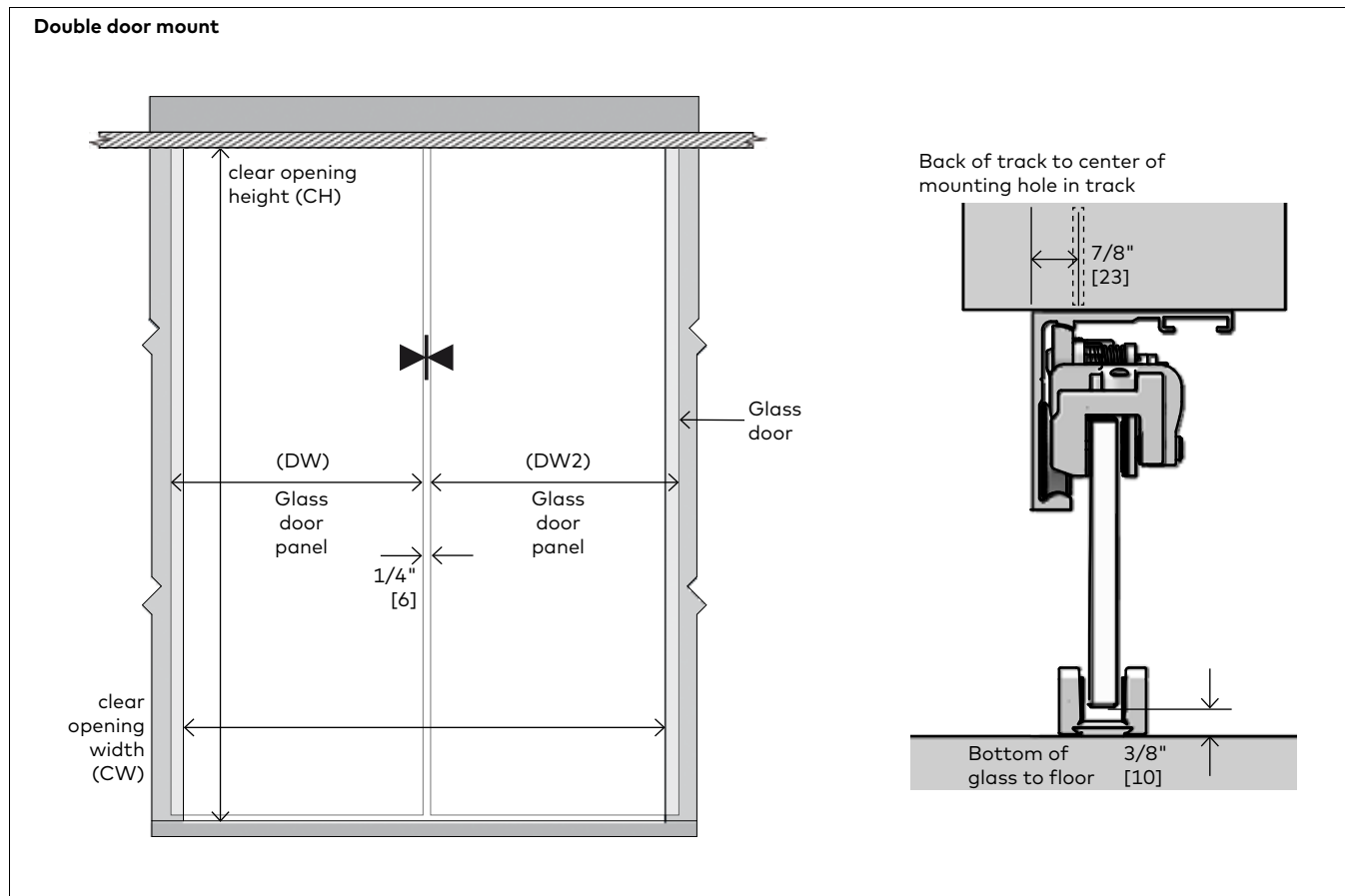
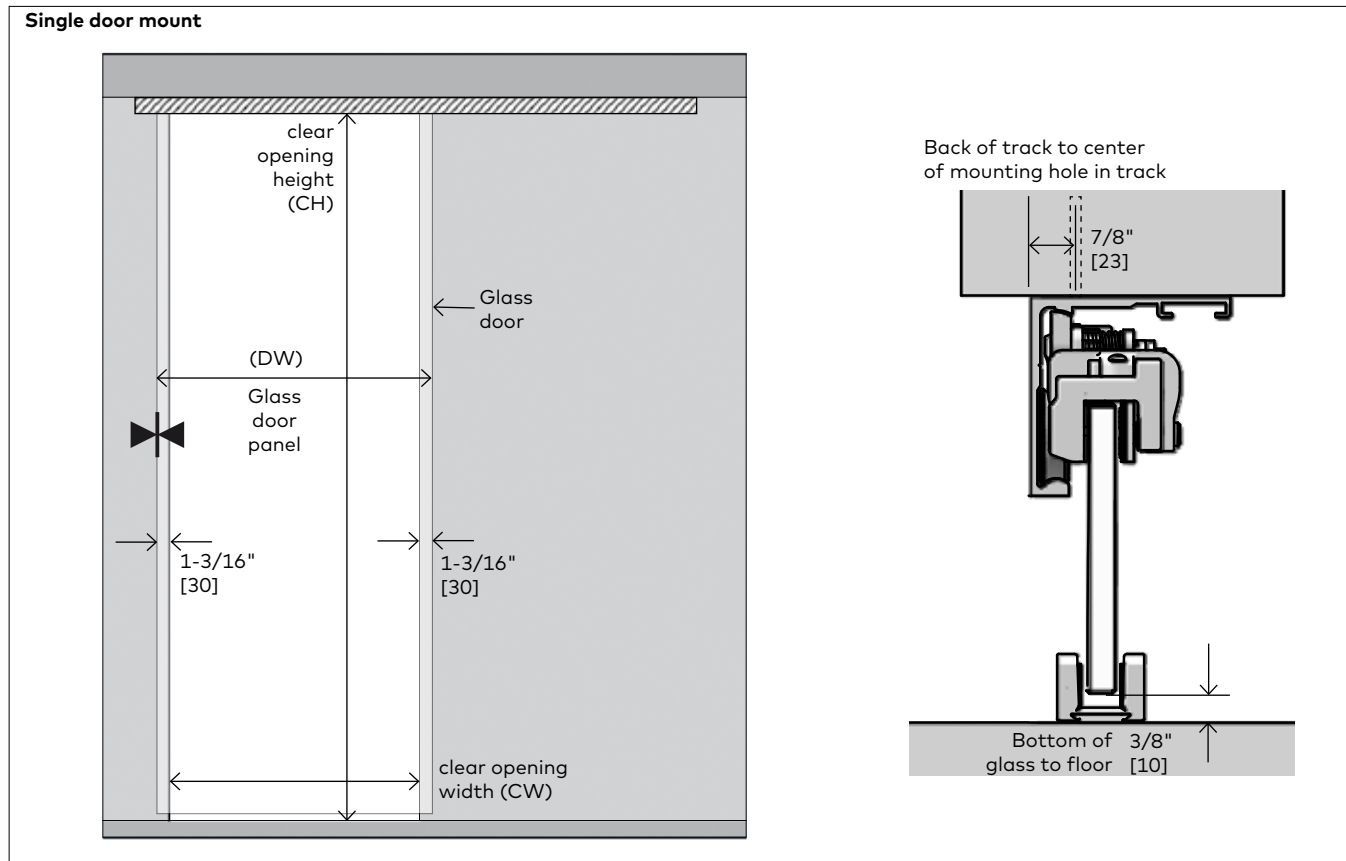

2.4A Installing roller carriers: on monolithic glass ONLY

Fig. 4

DETERMINE THE LEADING (X) VERSUS TRAILING (Z) EDGE OF THE GLASS.
"LEADING IS SIDE CLOSEST TO LATCH CLOSED."

Roller location on glass with DORMOTION unit

		XL150/80
Single door	X	3-1/8" [80]
Single door	Z	1-9/16" [40]
Double door	X	1-9/16" [40]
Double door	Z	2-3/8" [60]

Secure

Roller carrier

Legend	
	Closing edge of door

Torque values	
XL150/80	10ft lbs [14Nm]

Hex key size	
XL150/80	4mm

NOTE: FULLY CLEAN SURFACE OF GLASS WITH AN ALCOHOL-BASED MILD GLASS AND SURFACE CLEANER.

ENSURE GASKET IS FREE OF DEBRIS.

ENSURE ROLLER CARRIER WHEELS ARE FREE OF DEBRIS.

2.4A.1 Slide roller carriers onto glass.

2.4A.2 Slide glass gasket and metal shim between glass and roller carrier.

• **NOTE: Orient gasket with rubber side facing the glass.**

2.4A.3 Secure roller carriers to glass using appropriate-size hex key at 10 ft lbs [14 Nm].

2.4B Installing roller carriers: on tempered laminate glass ONLY

Fig. 5

⚠ DETERMINE THE LEADING (X) VERSUS TRAILING (Z) EDGE OF THE GLASS.
"LEADING IS SIDE CLOSEST TO LATCH CLOSED."



Roller location on glass with DORMOTION unit			
XL150/80			
Single door	X	3-1/8"	[80]
Double door	X	1-9/16"	[40]
Single door	Z	1-9/16"	[40]
Double door	Z	2-3/8"	[60]

Legend	
	Closing edge of door
Hex key size	
XL150/80	4mm
Torque values	
XL150/80	4ft lbs [5Nm]

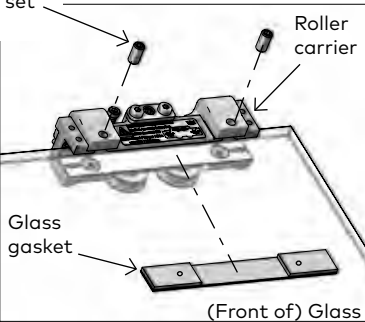

Secure with vented set screws

Roller carrier

Glass gasket

(Front of) Glass

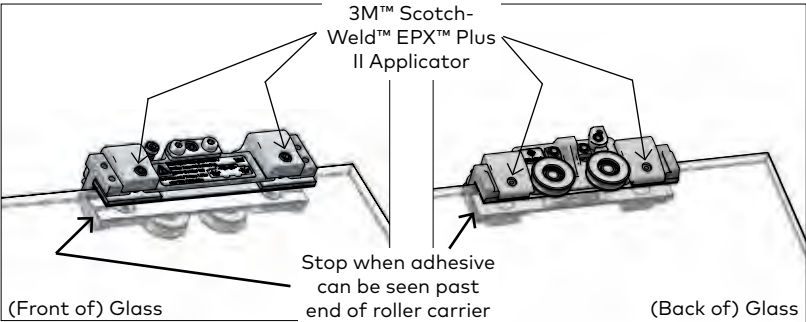

3M™ Scotch-Weld™ EPX™ Plus II Applicator

Stop when adhesive can be seen past end of roller carrier

(Front of) Glass

(Back of) Glass

⚠ NOTE: THE RECOMMENDED ADHESIVE'S SET-UP TIME IS 20 MINUTES FOR THE DUO-PAK CARTRIDGES.

⚠ NOTE: USE 1:1 RATIO PLUNGER WITH THE 3M™ Scotch-Weld™ Urethane Adhesive.

⚠ NOTE: FULLY CLEAN SURFACE OF GLASS WITH AN ALCOHOL-BASED MILD GLASS AND SURFACE CLEANER. ENSURE NO DEBRIS IS ON THE GASKET.

⚠ ENSURE ROLLER CARRIER WHEELS ARE FREE OF DEBRIS.

2.4B.1 Slide carriers onto glass.

2.4B.2 Replace existing gasket with TLG gasket.

2.4B.3 Slide laminated glass gasket and metal shim between glass and roller carrier.

NOTE: Orient gasket with rubber side facing the glass.

2.4B.4 Replace existing set screws with vented set screws.

2.4B.5 Tighten vented set screws at 4 ft lbs [5Nm].

NOTE: Onto scrap material, first dispense approximately 12" of 3M™ Scotch-Weld™ Urethane Adhesive prior to application to prevent mixing errors and ensure optimal hardening.

2.4B.6 Dispense adhesive into vented set screws on both sides of carrier.

⚠ Stop application when adhesive can be seen past edge of roller carrier.

⚠ DO NOT WIPE any excess adhesive from glass surface. Allow adhesive to dry and scrape off glass surface with a beveled-edge chisel or putty knife.

NOTE: Keep glass flat during curing process.

NOTE: See chart in Specifications section for appropriate curing time.

2.5 Install DORMOTION start/stop

Fig. 6

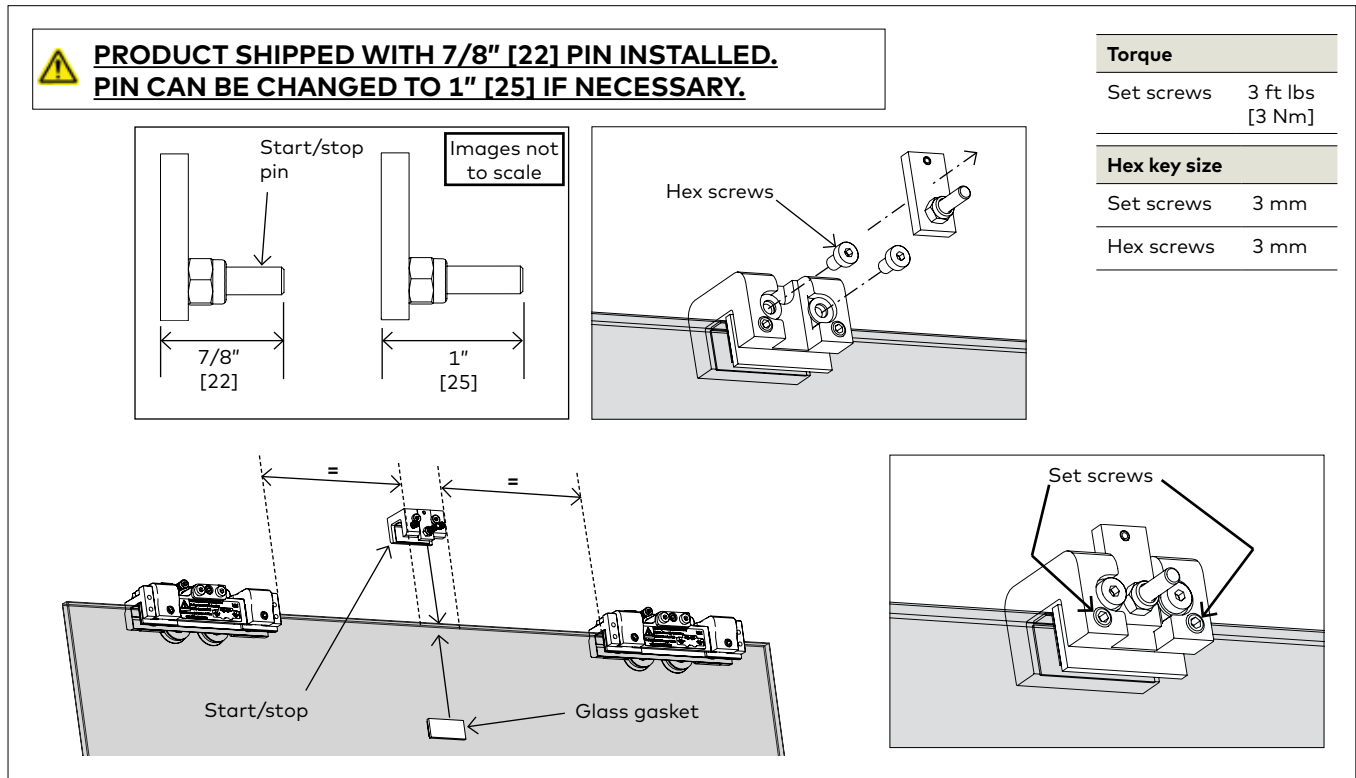

NOTE: Determine a pin length based upon how square and plumb the opening is.

- 2.5.1 If required, change pin in start/stop assembly.
- Remove hex screws.
 - Remove existing pin and plate.
 - Swap in appropriate pin and plate.
 - Replace hex screws.

2.5.2 Slide start/stop onto glass.

2.5.3 Center equally between the carriers.

2.5.4 Slide glass gasket between start/stop and glass.

NOTE: Orient with gasket facing glass.

2.5.5 Secure start/stop via set screws.

2.6 Disengaging the anti-jump

Fig. 7

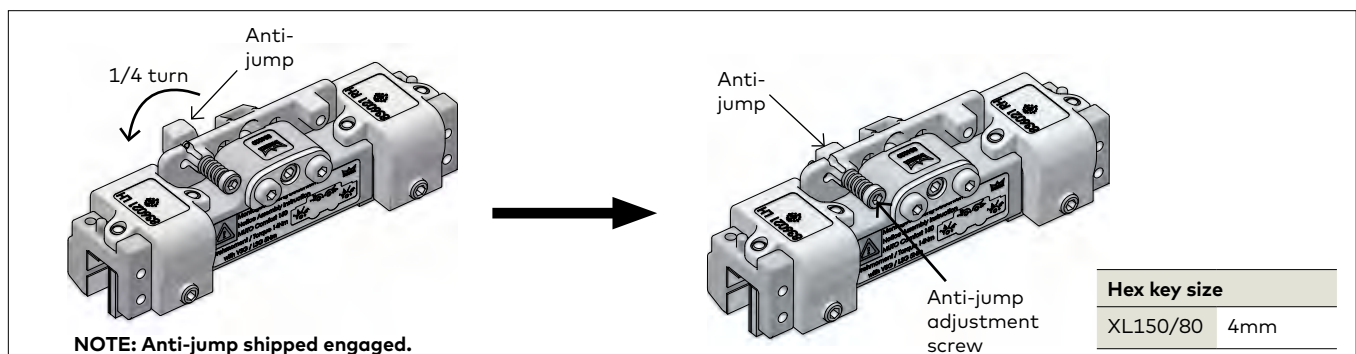

2.6.1 Disengage the anti-jump on roller carrier.

NOTE: Using the appropriate-size hex key, push anti-jump adjustment screw IN and turn **COUNTER-CLOCKWISE 90° to disengage** anti-jump.

2.7 Installing end stops

Fig. 8

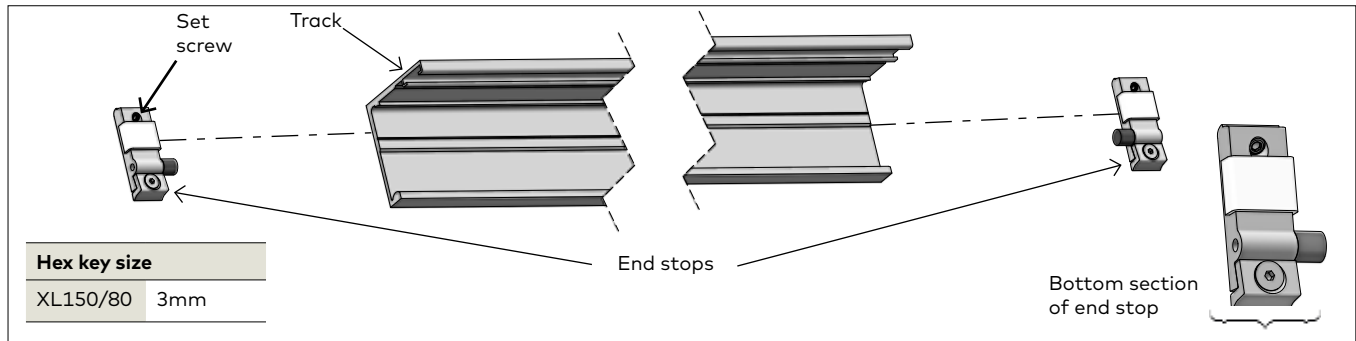

2.7.1 Slide end stops into each end of the track.
NOTE: Loosen bottom section of end stop for easier install.

NOTE: FOR XL150 end stops, be sure set screw is flush with back of end stops.

NOTE: Exact location/adjustments will be determined in "Adjustment End Stop Location" step.

2.8 Install glass/rollers in track

Fig. 9

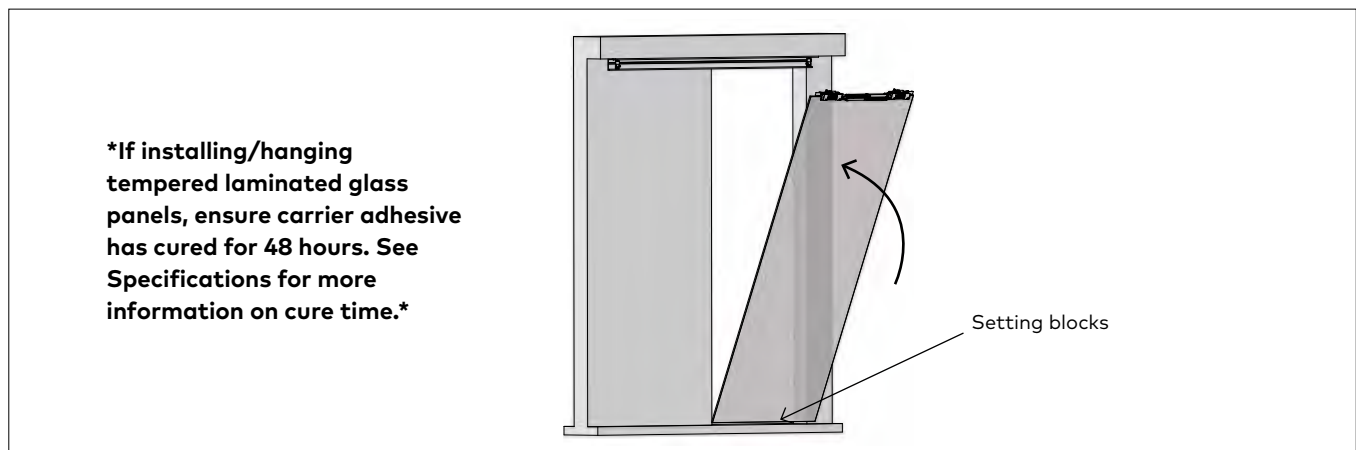

⚠ ENSURE ROLLERS AND TRACK ARE FREE OF DEBRIS.

2.8.1 Place glass on setting blocks on floor for stability.

2.8.2 Tip glass and rollers upward and rest rollers on track.

2.9 Install floor guide

Fig. 10

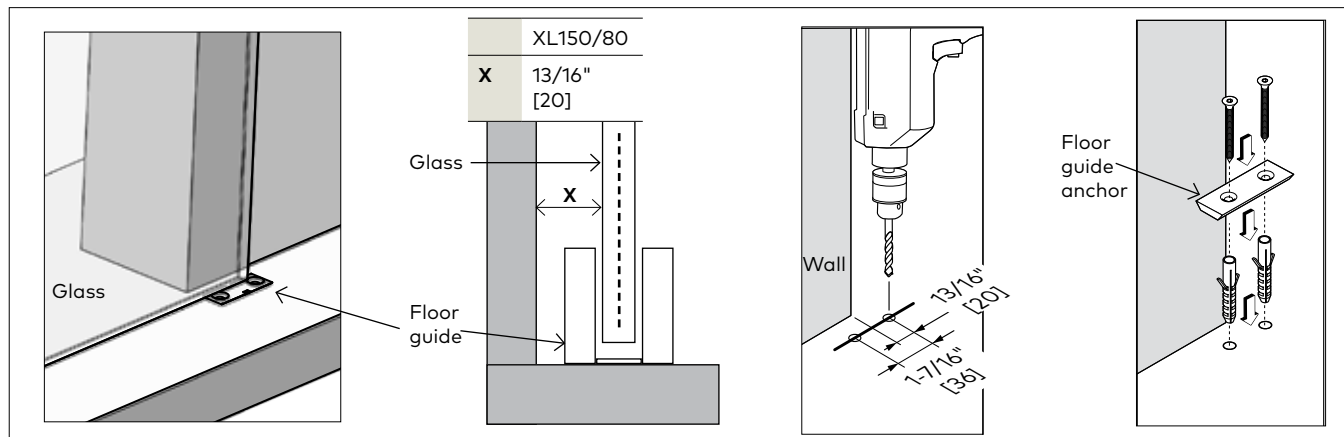

REMEMBER ANTI-JUMP IS DISENGAGED!

2.9.4

TEMPORARILY REMOVE GLASS AND ROLLERS FROM TRACK (TO ALLOW FOR DRILLING SPACE).

2.9.1 Align centerline of glass with centerline of floor guide.

2.9.5

Pre-drill into mounting surface using a 5/16" drill bit.

2.9.2 Be sure the glass is plumb.

2.9.6

Secure floor guide anchor with included fasteners.

2.9.3 Mark appropriate floor guide measurements.

2.10 Install floor guide: contiued

Fig. 11

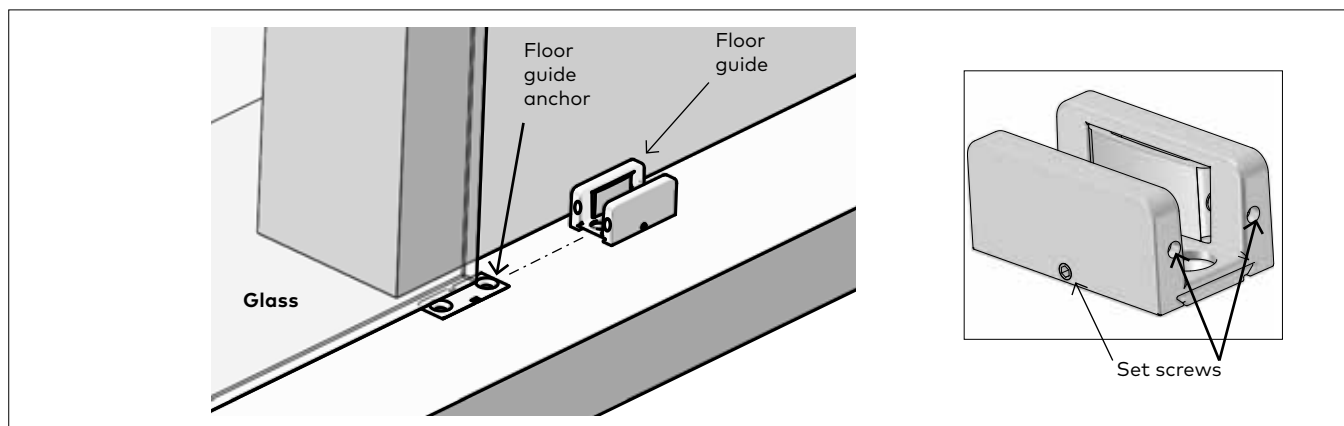

2.10.1 **SET GLASS AND ROLLERS BACK ONTO TRACK.**

2.10.3 Remove setting blocks.

2.10.2 Slide floor guide over floor guide anchor and tighten with set screws.

NOTE: Be sure glass is centered in floor guide.

2.10.4 Adjust using set screws.

2.11 Engaging anti-jump

Fig. 12

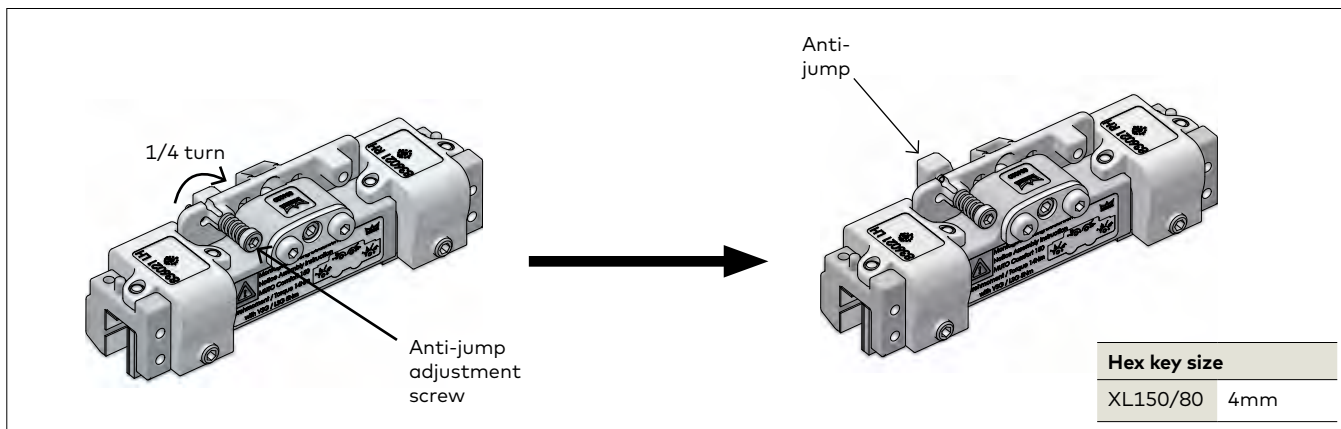

2.11.1 Engage anti-jump on roller carrier.

2.11.2 Using appropriate-size hex key, push anti-jump adjustment screw **IN** and turn **CLOCKWISE** 90° to **engage** anti-jump.

2.12 Adjustment door height

Fig. 13

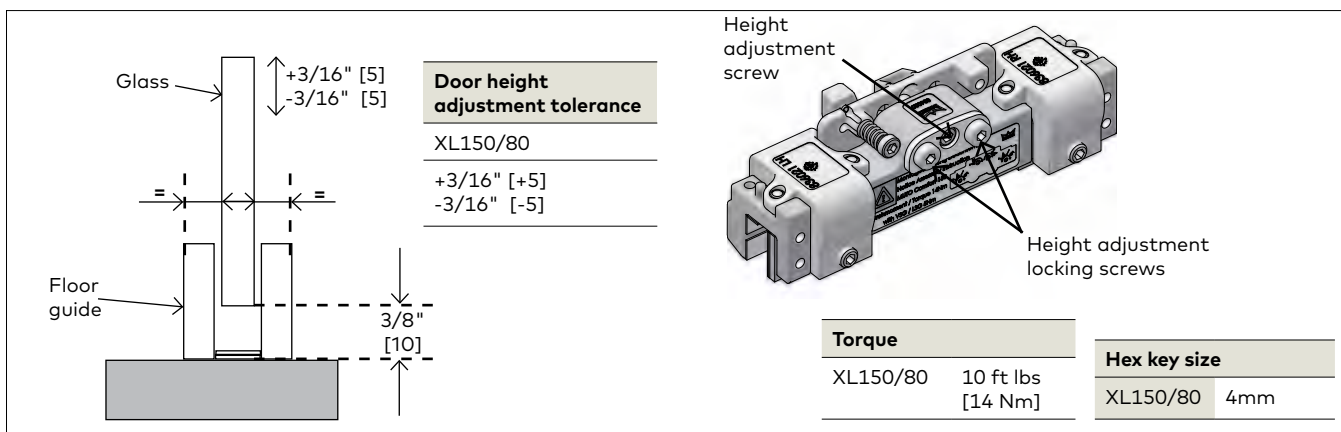

2.12.1 Set height of glass door.

2.12.2 Loosen height adjustment locking screws of carrier.

2.12.3 Using appropriate-size hex key, turn height adjustment screw **CLOCKWISE** or **COUNTER-CLOCKWISE** to raise or lower glass.

NOTE: Be sure glass is level during this adjustment.

2.13 Adjustment end stop location: LEADING end stop

Fig. 14

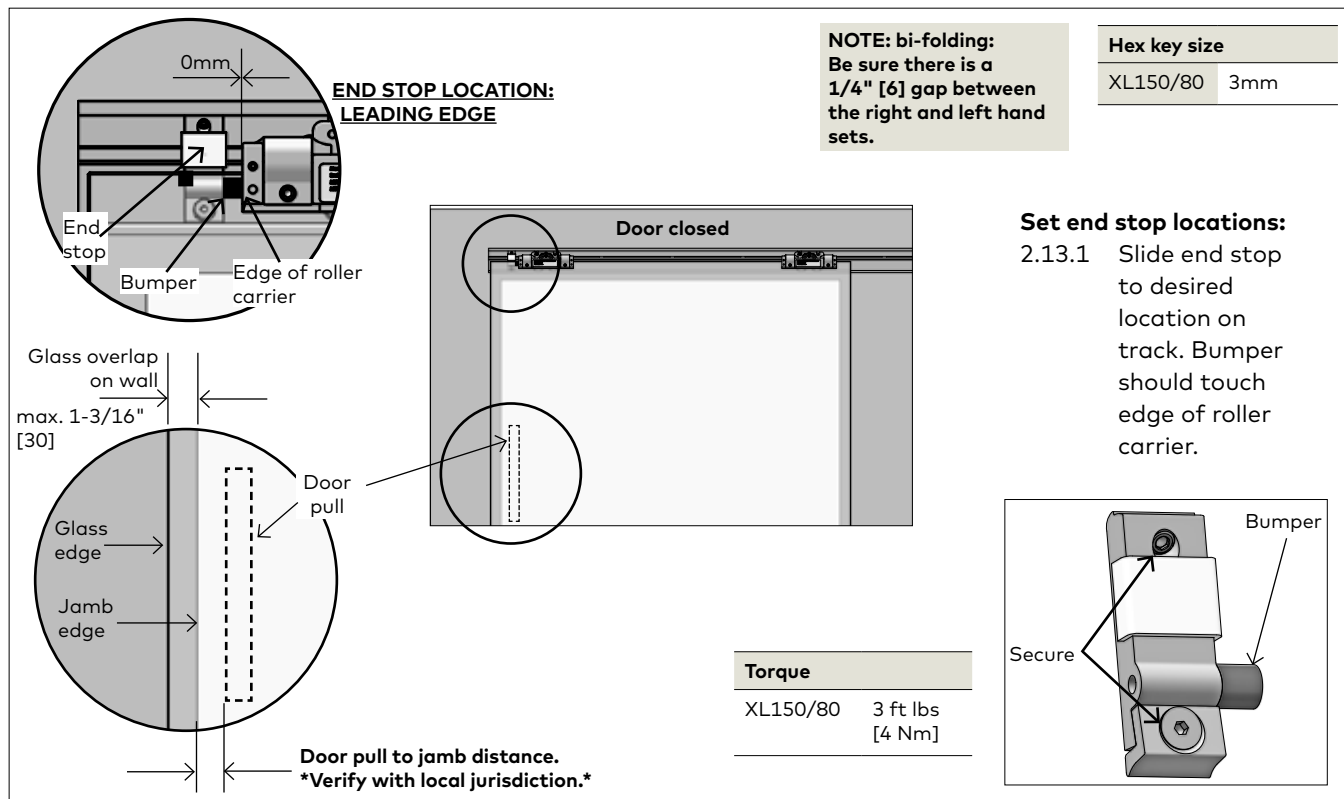

Adjustment end stop location: TRAILING end stop

Fig. 15

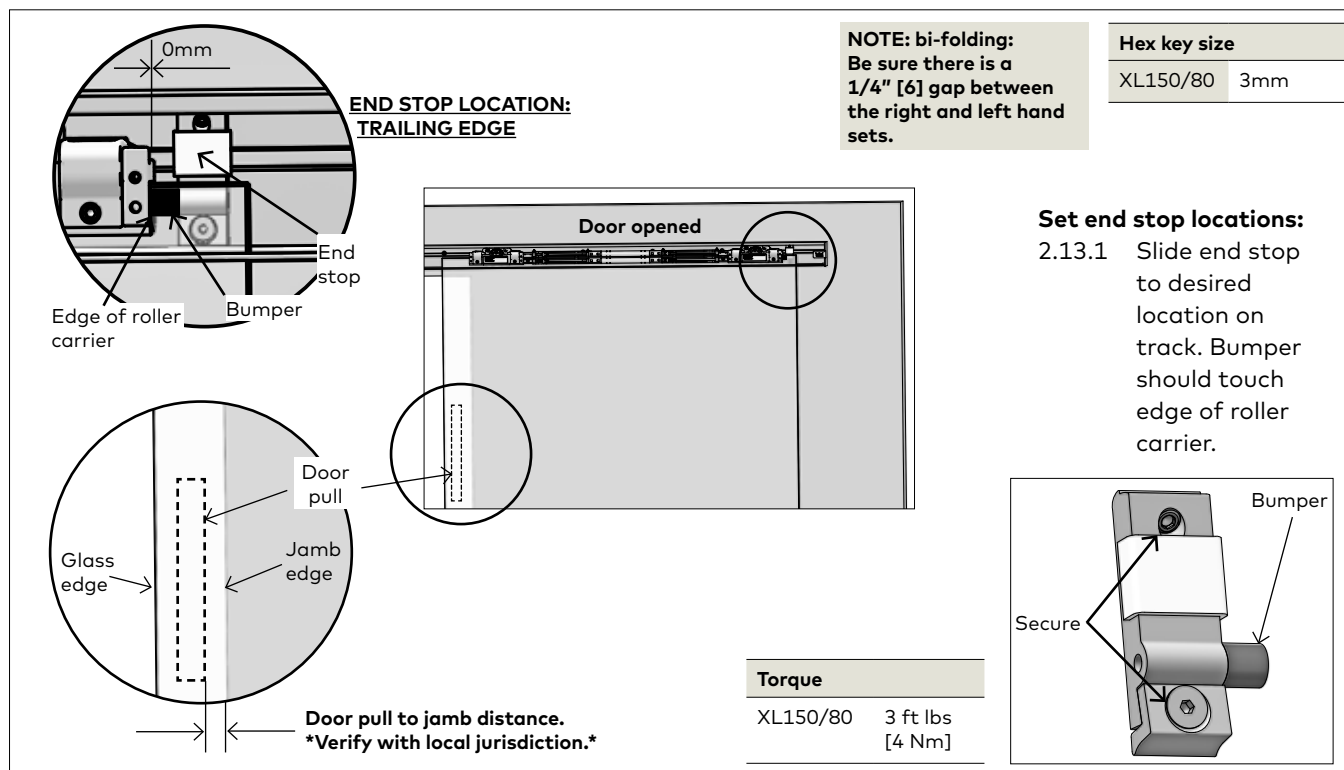

2.14 Install DORMOTION units

Fig. 16

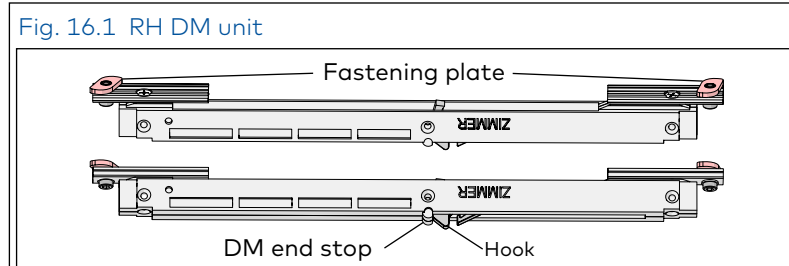

Fig. 16.2 RH DM unit fastening plates rotated

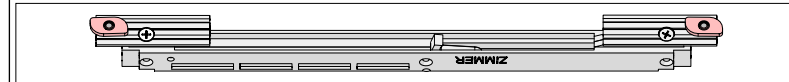

Fig. 16.3 RH DM unit inserted in track

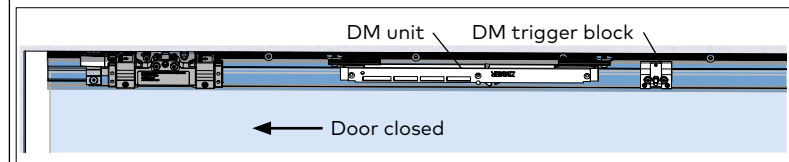

Fig. 16.4 DM unit hook positioned in trigger

DM hook
DM end stop
Trigger

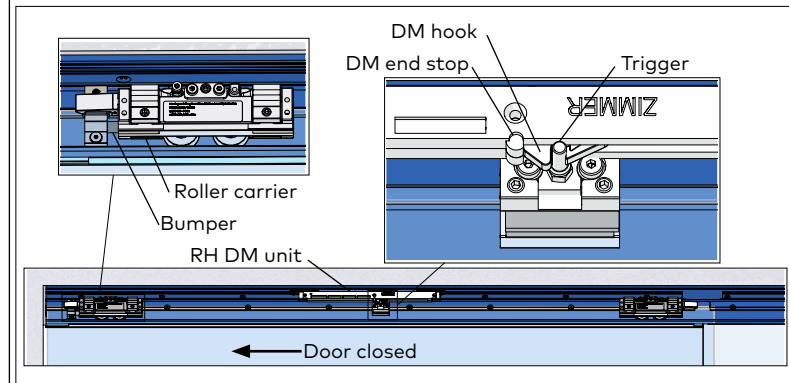

Fig. 16.5 DM unit end stop and hook separation adjustment

Adjustment tool
Fork
Fork gap
DM end stop
DM hook
Trigger

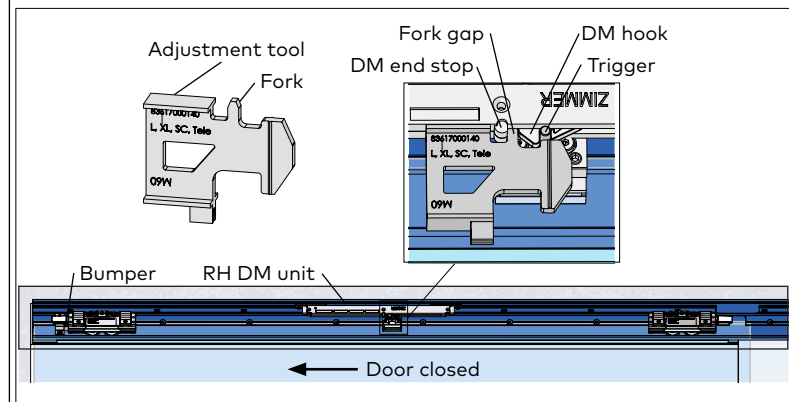
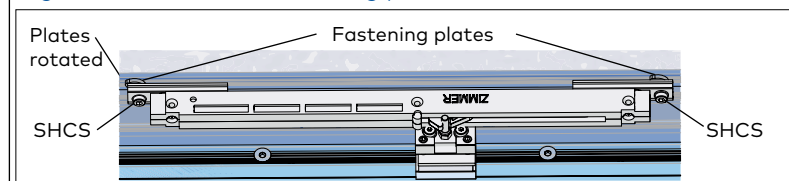

Fig. 16.6 RH DM unit fastening plates secured in track

Plates rotated
Fastening plates
SHCS



RH Dormotion -door closed

2.14.1 Rotate RH DM fastening plates.

- Using 4 mm hex key, loosen fastening plate hex screws.
- Rotate fastening plates until they are parallel to the DM unit (Fig. 16.2)
- Snug hex screws.

2.14.2 Move door to close position.

- For installation of RH DM unit, door must be in the closed position against bumper.

Fig. 16.7 RH DM unit aligned in track

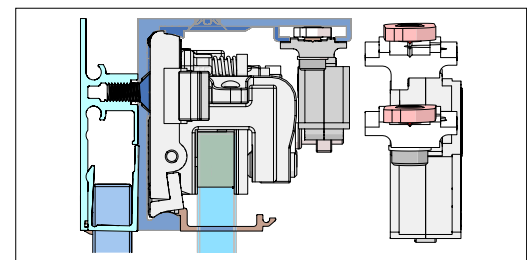

2.14.3 Align DM unit in track, engage DM hook in DM trigger.

- Align DM unit in track (Fig. 16.7).
- Slide DM unit over the DM trigger block until the DM hook engages the DM trigger (Fig. 16.4)

2.14.4 Use adjustment tool to set DM unit final position.

- Place adjustment tool flat against DM unit with fork between DM hook and DM end stop (Fig. 16.5).
- Slide DM unit over until hook and DM end stop are against the fork. This sets 5 mm gap (fork gap).
- **Trigger height:** Adjust so trigger sets on top of adjustment tool (Para. 2.15).

2.14.5 Secure the DM unit in position.

- NOTE: Insure door is fully closed against bumper before performing this step.
- Using 4 mm hex key, tighten DM unit fastening plate socket head cap screws. Fastening plates must engage the track (Fig. 16.6 and .8).

Torque

Socket head cap screws 3 ft lbs [4 Nm]

Fig. 16.8 RH DM unit installed in track

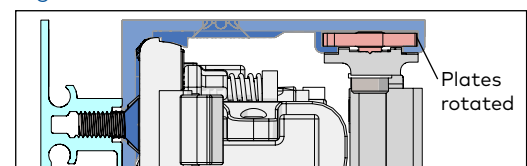

Fig. 16 (Con't)

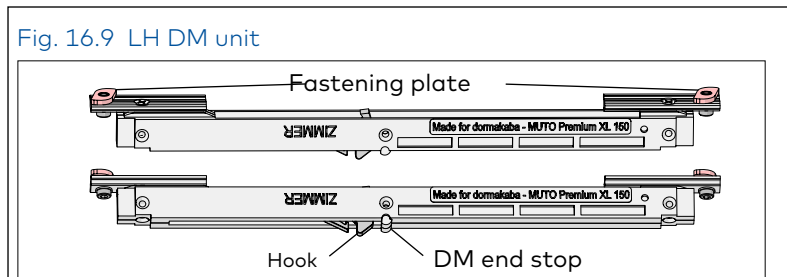

Fig. 16.10 LH DM unit fastening plates rotated

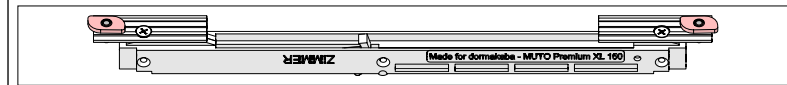

Fig. 16.11 LH DM unit inserted in track

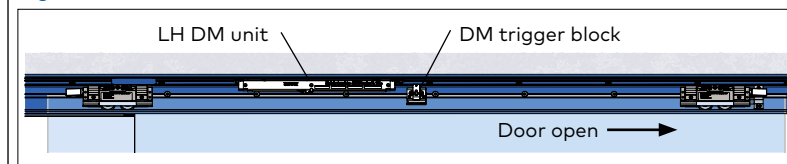

Fig. 16.12 DM unit hook positioned in trigger

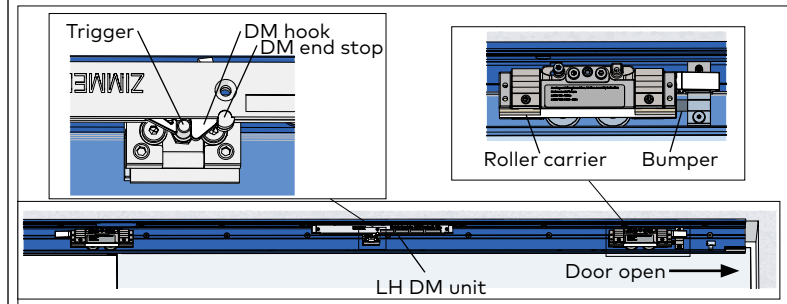

Fig. 16.13 DM unit end stop and hook separation adjustment

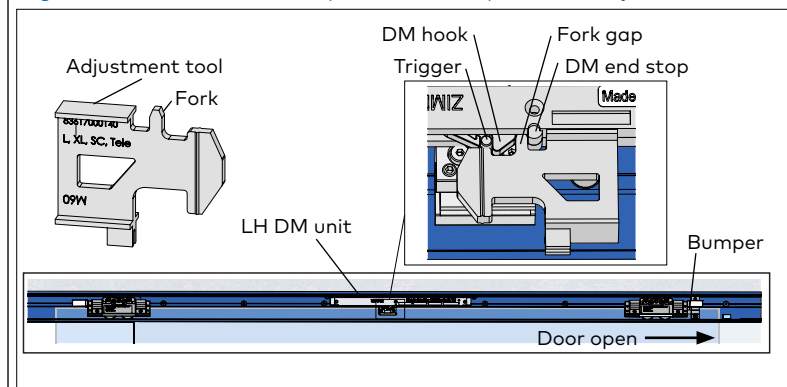
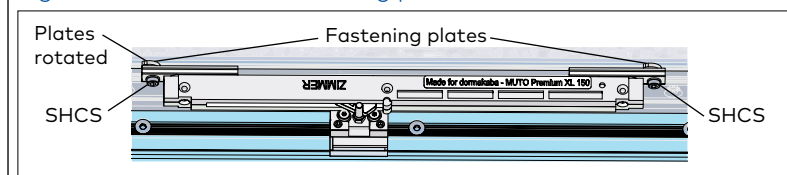

Fig. 16.14 LH DM unit fastening plates secured in track



LH Dormotion -door open

2.14.6 Rotate DM fastening plates.

- Using 4 mm hex key, loosen fastening plate hex screws.
- Rotate fastening plates until they are parallel to the DM unit (Fig. 16.10)
- Snug hex screws.

2.14.7 Move door to open position.

- For installation of LH DM unit, door must be in the open position against bumper.

Fig. 16.15 LH DM unit aligned in track

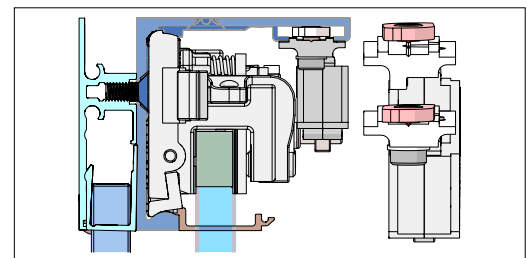

2.14.8 Align DM unit in track, engage DM hook in DM trigger.

- Align DM unit in track (Fig. 16.15).
- Slide DM unit over the DM trigger block until the DM hook engages the DM trigger (Fig. 16.12)

2.14.9 Set DM unit final position.

- Place adjustment tool flat against DM unit with fork between DM hook and DM end stop (Fig. 16.13).
- Slide DM unit over until hook and DM end stop are against the fork. This sets 5 mm gap (fork gap).
- **Trigger height:** Adjust so trigger sets on top of adjustment tool (Para. 2.15).

2.14.10 Secure the DM unit in position.

- NOTE: Insure door is fully open against bumper before performing this step.
- Using 4 mm hex key, tighten DM unit fastening plate socket head cap screws . Fastening plates must engage the track (Fig. 16.16).

Torque

Socket head cap screws 3 ft lbs [4 Nm]

Fig. 16.16 LH DM unit installed in track

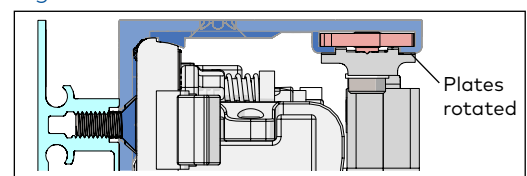

2.15 Adjust start/stop pin height (if necessary)

Fig. 17

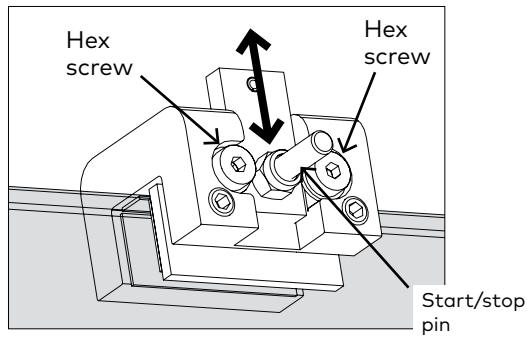

2.15.1 Adjust HEIGHT of start/stop pin, if necessary:

- Loosen hex screws.
- Slide pin and plate up or down.

Hex key size	
Hex screws	3 mm

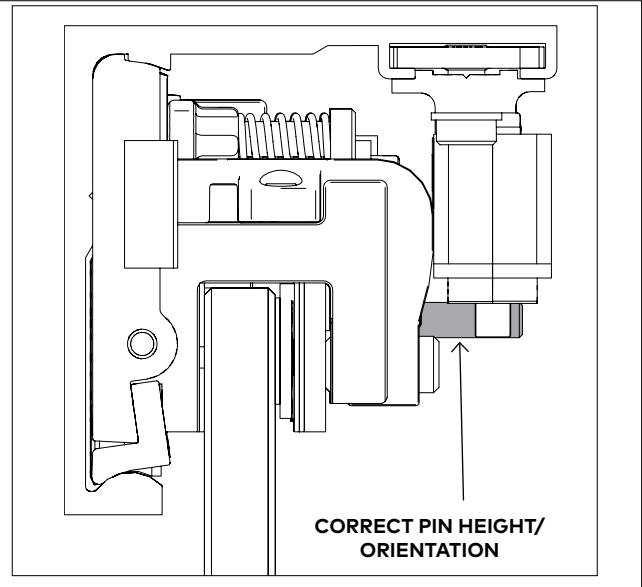

2.16 Install Cover clips

Fig. 18

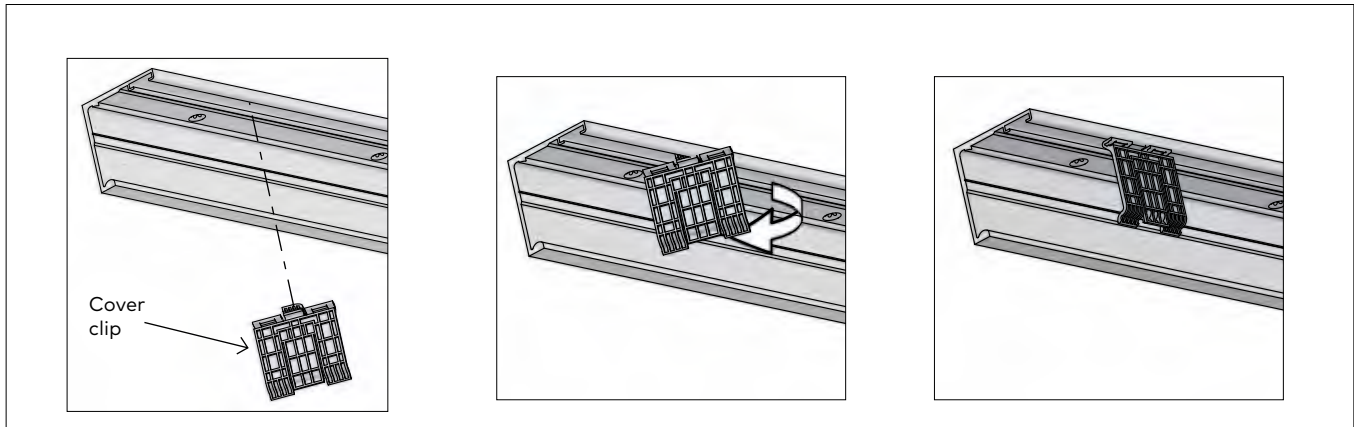

2.16.1 Insert cover clips into track. (One clip per foot)

2.16.2 Insert perpendicular to track, and turn **CLOCKWISE** to snap into place.

2.17 Install brush profile

Fig. 19

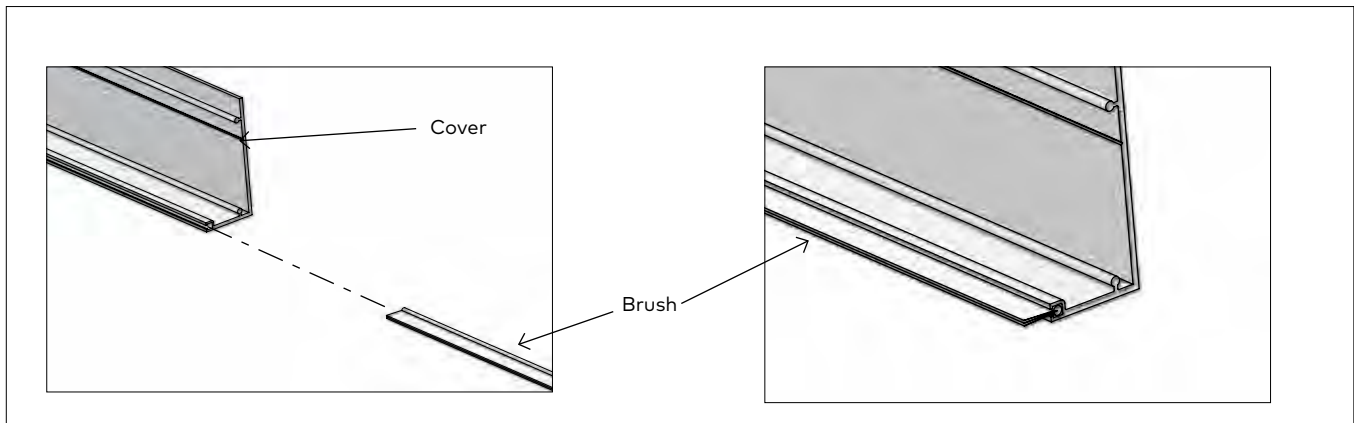

2.17.1 Measure and cut brush to appropriate length.

2.17.2 Slide brush into cover.

2.18 Install view protection clips

Fig. 20

TO BE USED WITH ONE OR MULTIPLE SIDELITE APPLICATIONS.

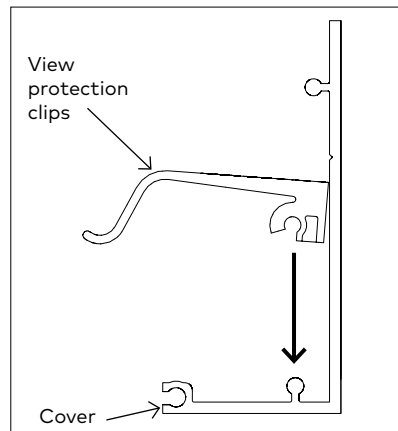
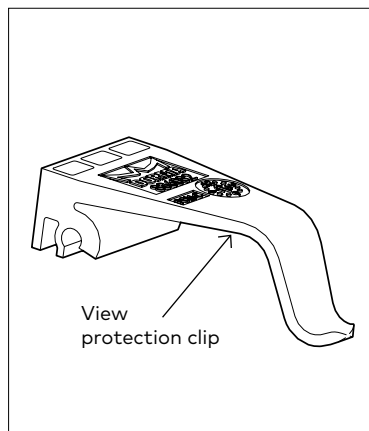
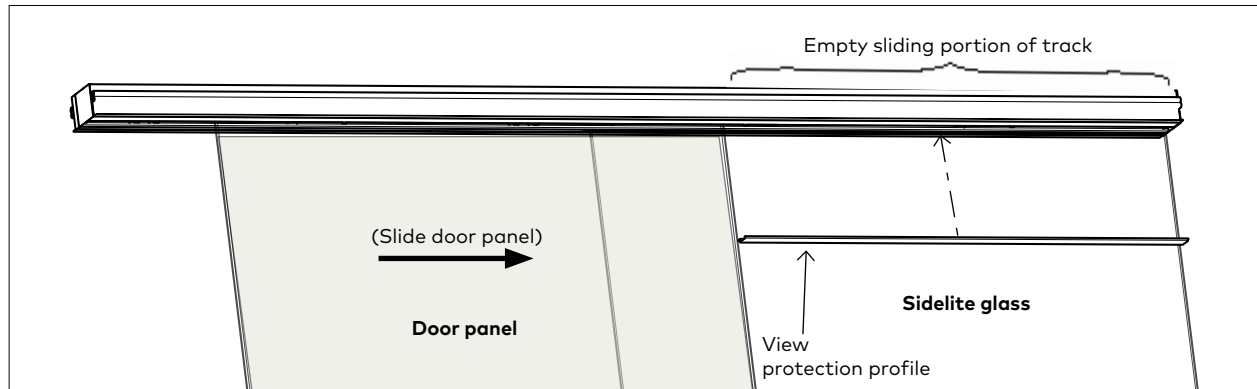

- 2.18.1 Slide door open until it meets the end stop.
- 2.18.2 Measure and cut view protection profile to fit into empty sliding portion of track - 3/16" [5].
- 2.18.3 Snap view protection clips onto inside of cover as shown.

- 2.18.4 Use minimum 1 clip per foot of profile.

Exception: If profile is minimum of 1 foot in length, use 2 clips.

2.19 Install cover and view protection profile

Fig. 21

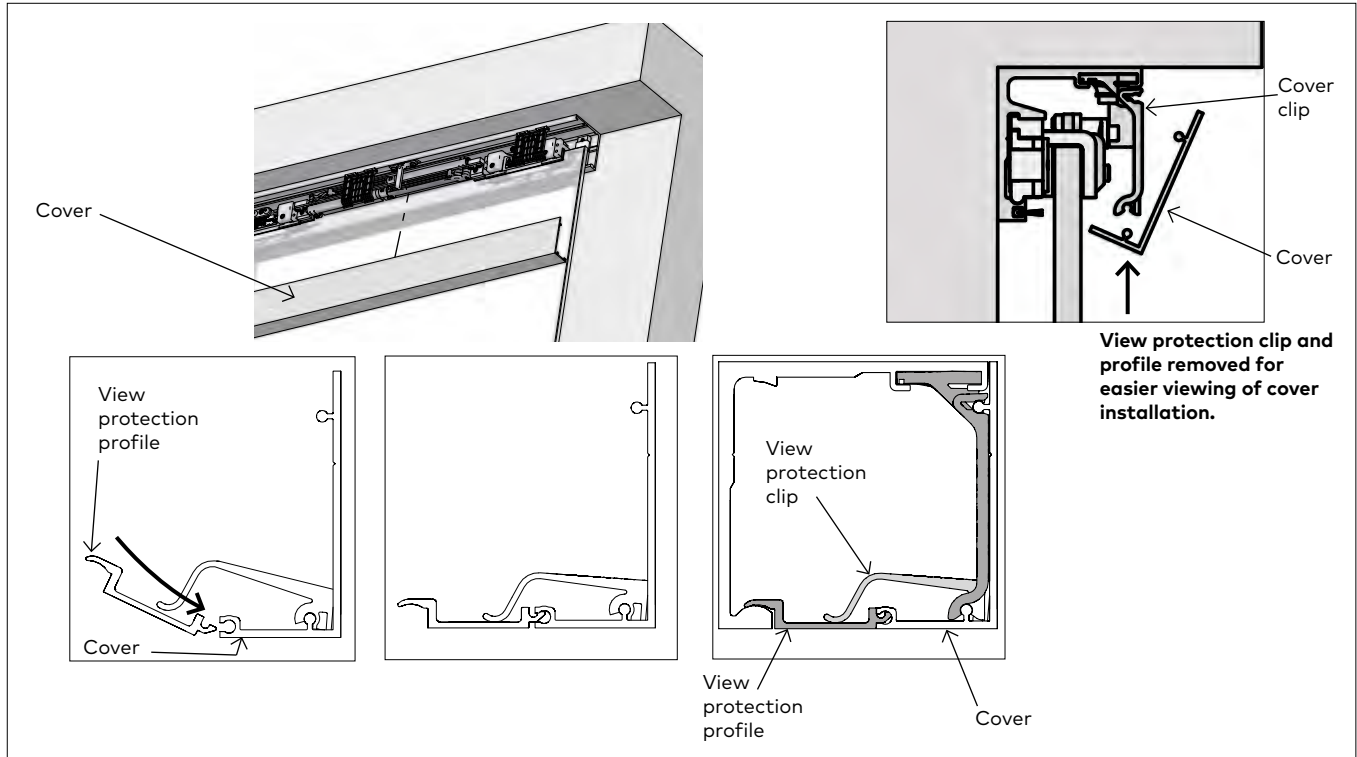

2.19.1 Secure cover to clips and snap into place.
NOTE: Roll cover from the bottom upwards. Ensure the bottom of the cover is supported by the groove in the cover clip.

2.19.2 Tip view protection profile up into track and snap down into cover and onto track as shown.

2.20 Install end caps

Fig. 22

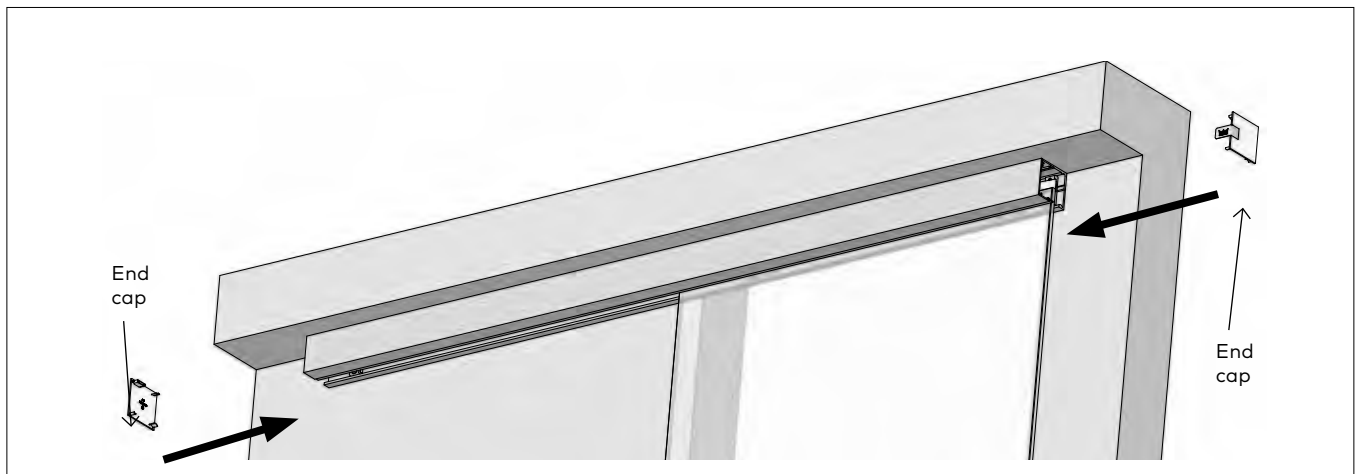

2.20.1 Snap end caps onto track.

This page left intentionally blank.



Scan for product details and downloads.

Call 800-523-8483 or visit
glasstechserv.us@dormakaba.com
for assistance or warranty information

dormakaba USA, Inc.
1 Dorma Drive, Drawer AC
Reamstown, PA 17567